

# 魅力4K/HDR现场制作

## 4K/HDR Technology for Live Operation

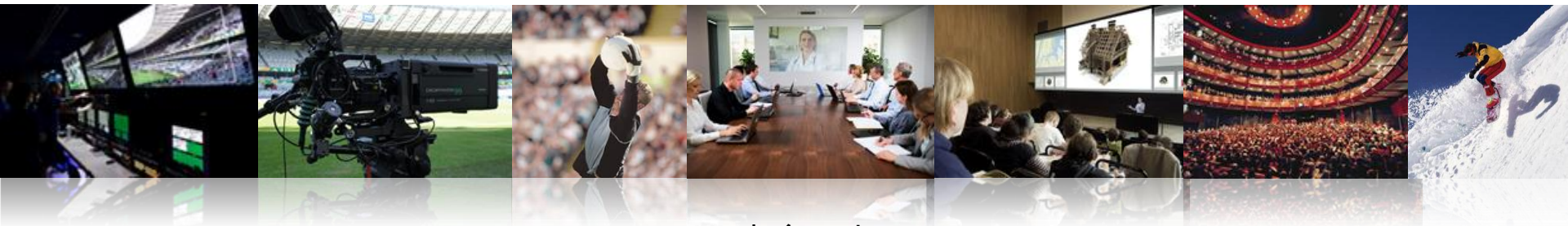

喜多干夫

索尼专业系统集团内  
容解决方案事业部  
高级部长

May 11th, 2016

# 高动态范围简介 An Introduction to HDR

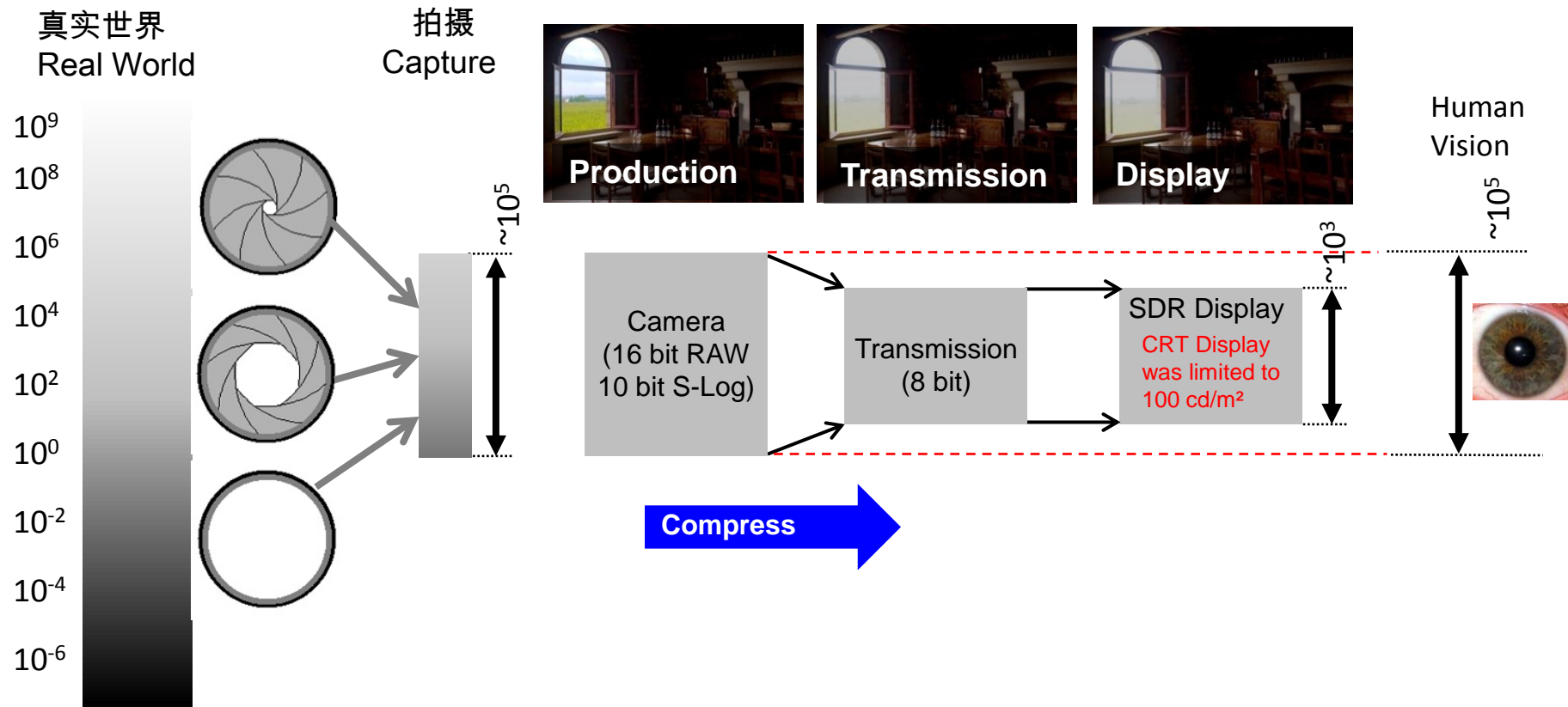

# 高动态范围简介 An Introduction to HDR

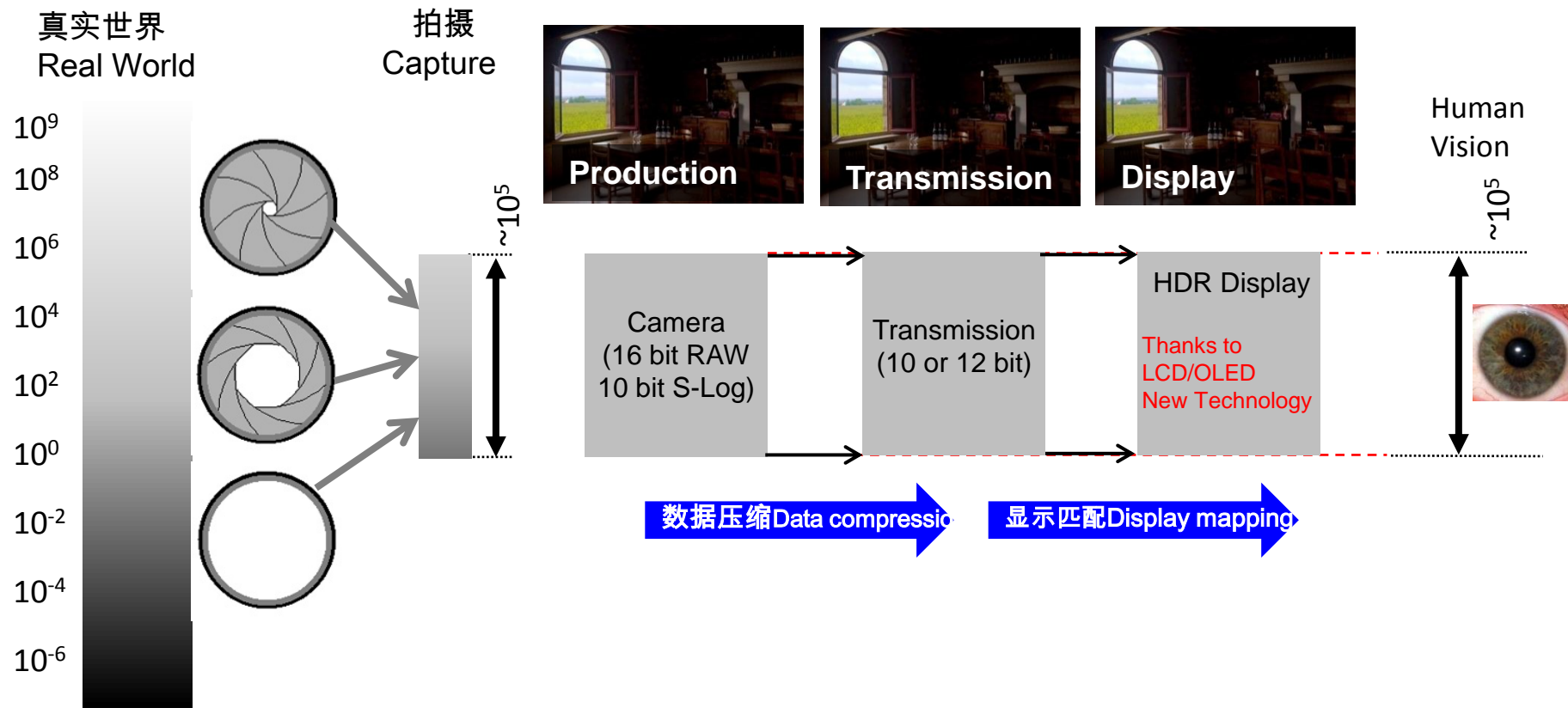

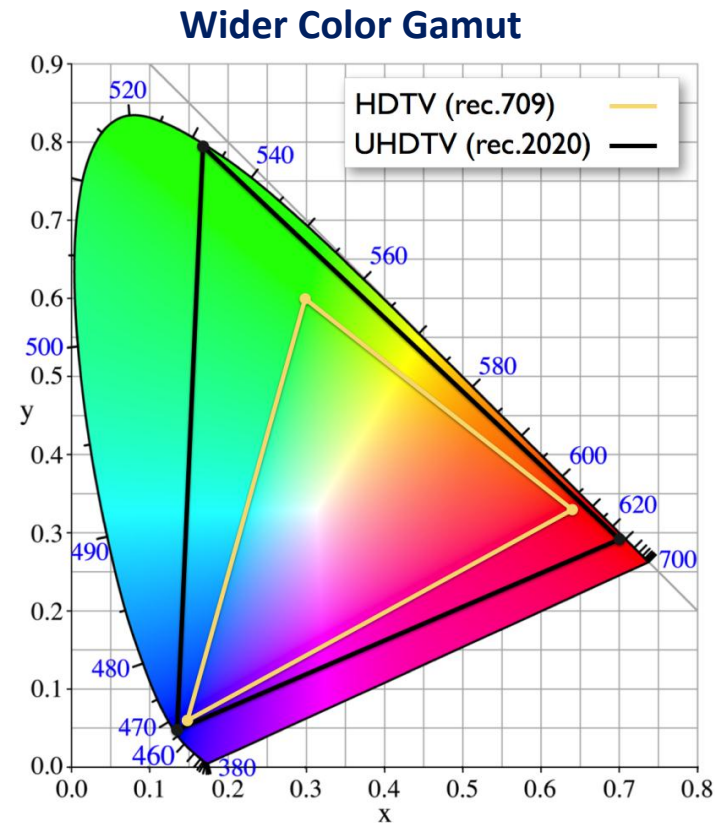
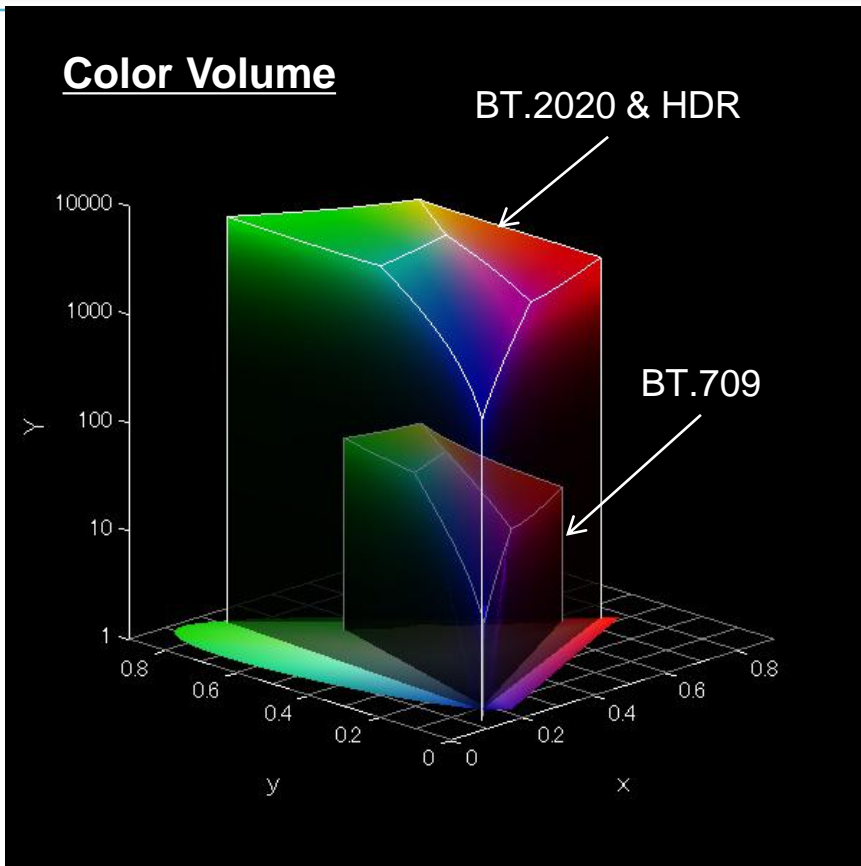

# 索尼是目前最好的HDR转播方案提供者

Sony is the Best HDR Solution Provider in the Market

SONY



电影  
Feature Film

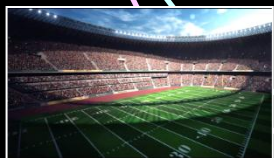

体育  
Sports



HDC-4300



PWS-  
4400/4500



XVS-8000



F65



PMW-F55



BVM-X300



广告  
Commercials



专题片  
Documentary

众多的HDR产品祝您创意无限

Wide range of HDR Products are here to enhance your Creativity!

# 高动态范围现场制作概观

## Overview of Live HDR Production

拍摄/信号源域  
Capturing/Source  
Domain

高动态范围制作域  
HDR Production  
Domain

信号分配域  
Distribution  
Domain

4K HDR  
S-Log3/BT2020

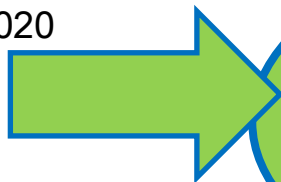

4K S-Log3/BT2020

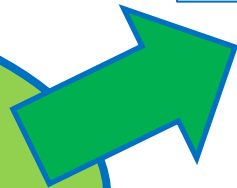
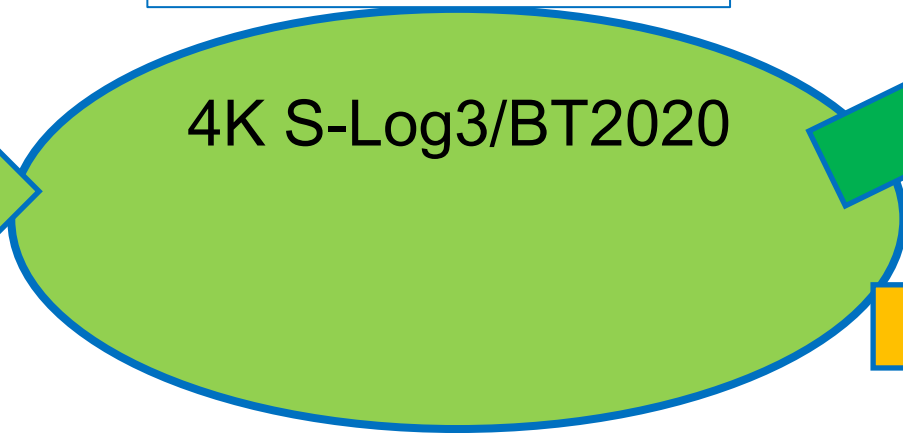

4K HDR (ST2084)  
4K HDR (HLG)

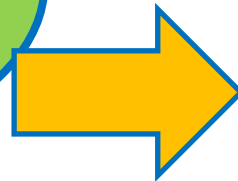

4K SDR

# 设备及工具

Equipment and tools?

HDC-4300/BPU-4000



XVS-8000



PWS-4500



F55/BPU-4000

BVM-X300



✓ **HDR READY**

需要我们改变现有的工作流程和人员配备吗？

~~Do we have to change the present workflow and/or staffing?~~

✓ 不必改变现有的标准动态范围（SDR）制作人员配备

You do not have change the present staffing for SDR production.

✓ 我们推荐新的4K设备用于标准动态范围制作环境

We would like to propose you to operate the new 4K gears in SDR production environment.

✓ 这才是实现高动态范围和标准动态范围同播的目标

That way you can achieve HDR/SDR simultaneous production.



# 高动态范围现场制作概观

## Overview of Live HDR Production

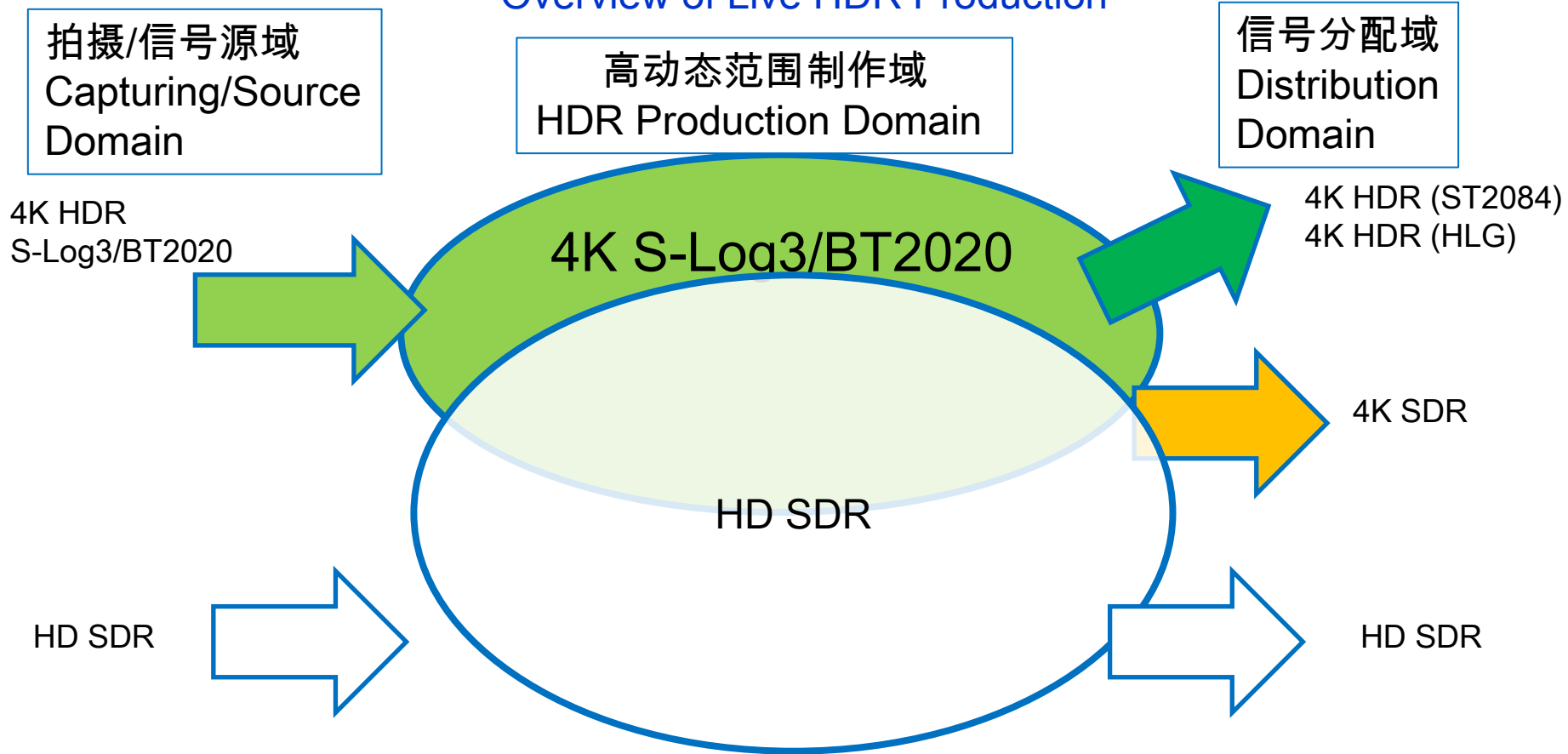

# 目前典型的高清现场制作

Typical HD Live Production, today

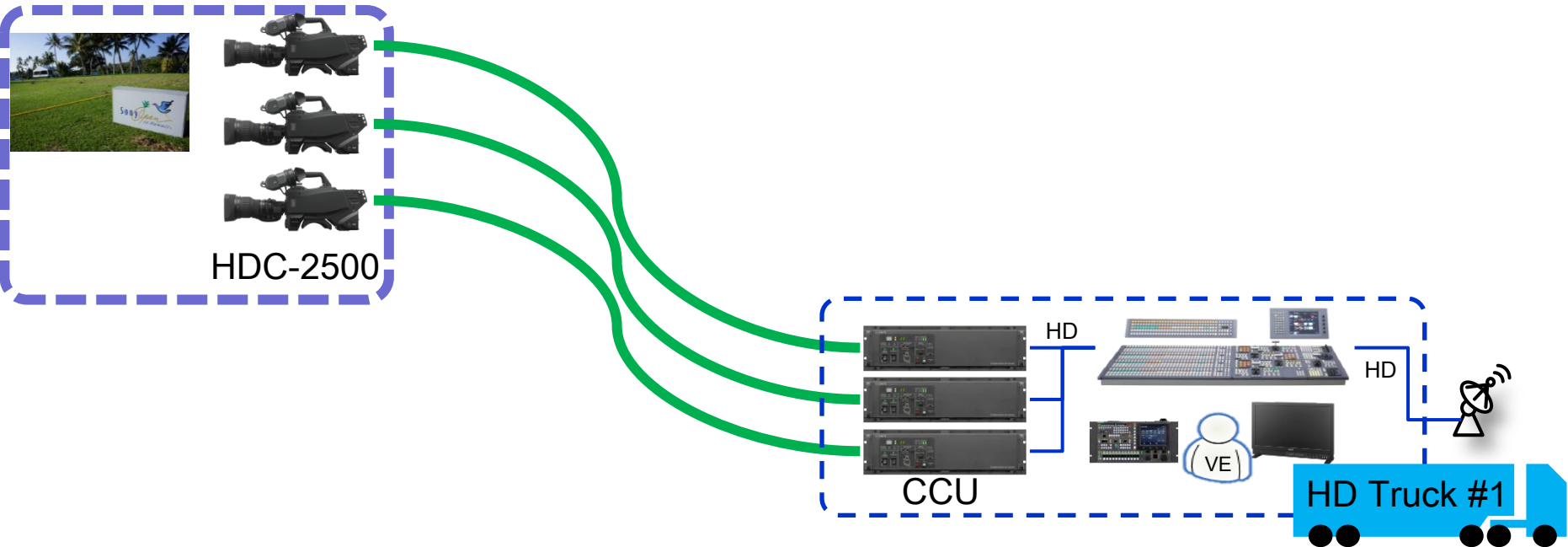

# 推荐的4K/HDR系统

## Proposed 4K HDR System

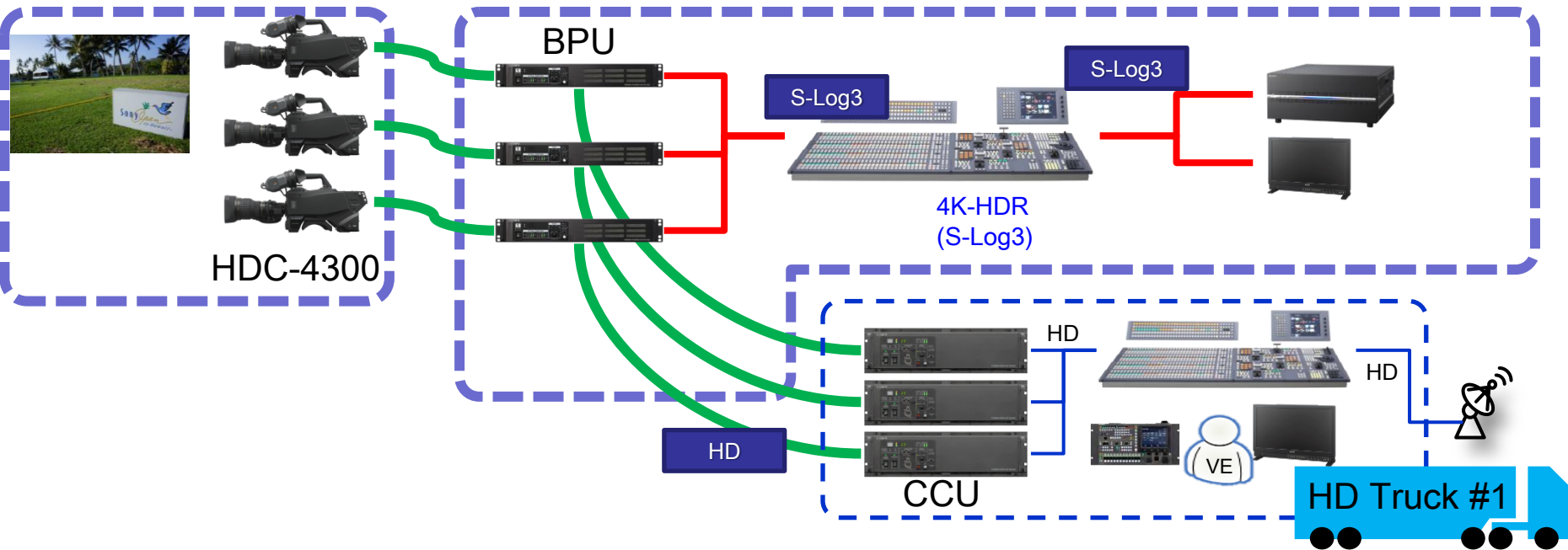

✓ 所有的SDR域的摄像机和光圈控制，自动同步反映在HDR域制作中  
All IRIS controls and/or Camera paintings in SDR domain,  
automatically reflected to HDR images

# 4K现场制作系统 HDC4300

4K-Live HDR System – HDC-4300

## 4KHDR与4KSDR同播/双播制作系统

4K-HDR & 4K-SDR Simultaneous/Dual Production

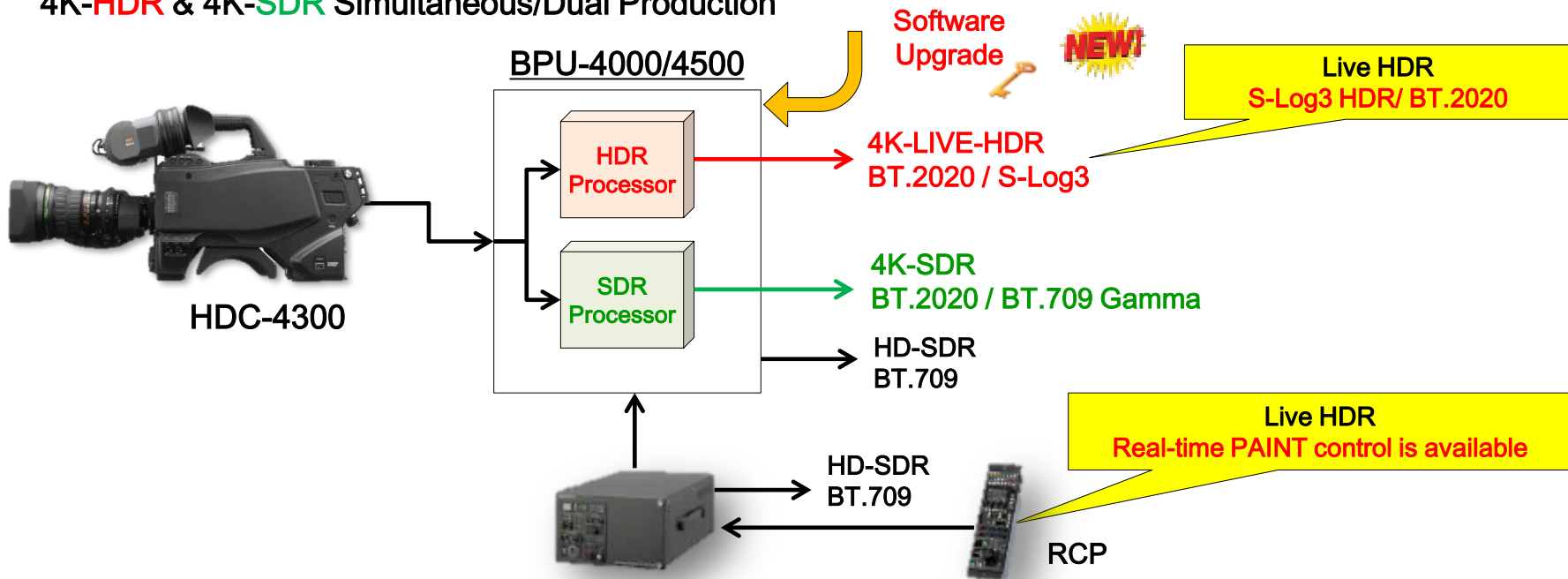

# 4K现场制作系统 HDC4300

4K-Live HDR System – HDC-4300

## 4KHDR与4KSDR同播/双播制作系统

4K-HDR & 4K-SDR Simultaneous/Dual Production

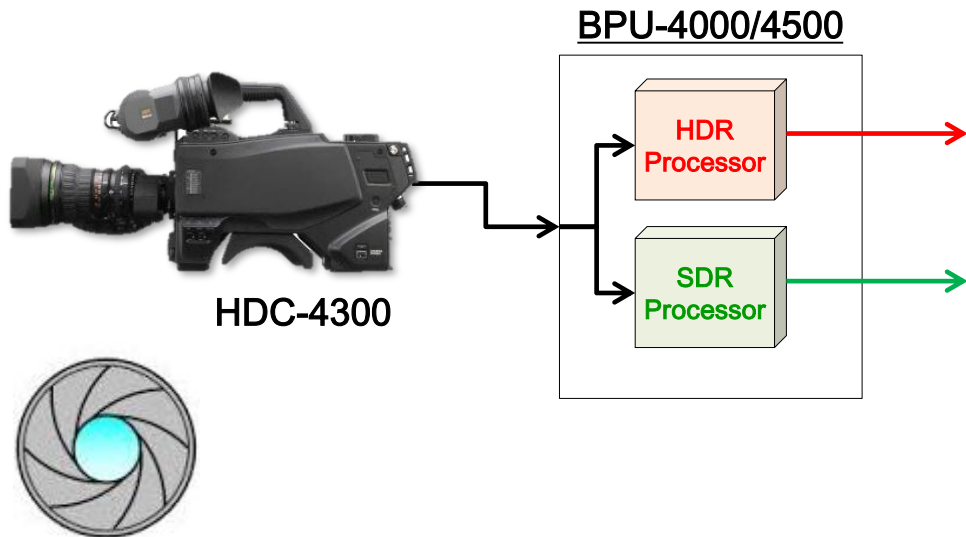

HDR



SDR

# 4K现场制作系统 HDC4300

4K-Live HDR System – HDC-4300

## 4KHDR与4KSDR同播/双播制作系统

4K-HDR & 4K-SDR Simultaneous/Dual Production

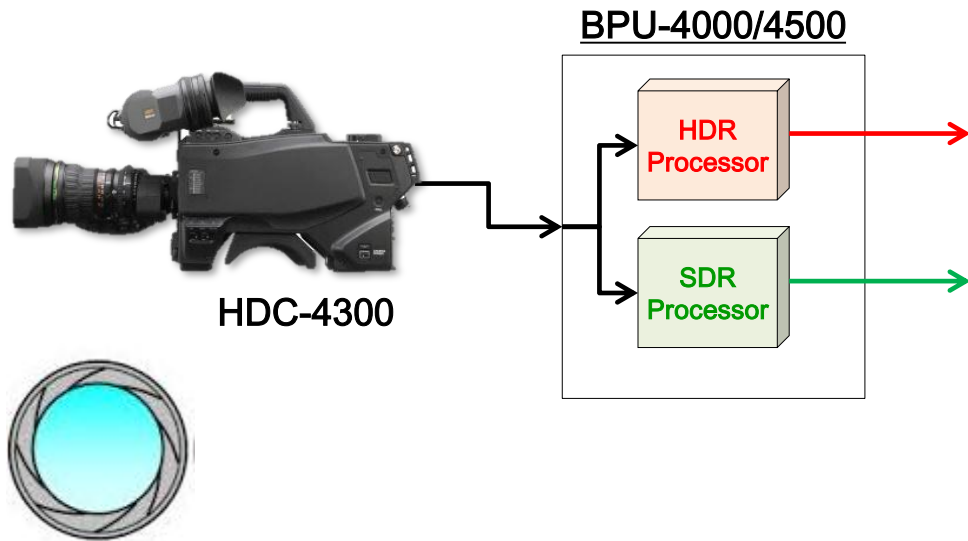

HDR



SDR

# 4K现场制作系统 HDC4300

4K-Live HDR System – HDC-4300

## 4KHDR与4KSDR同播/双播制作系统

4K-HDR & 4K-SDR Simultaneous/Dual Production

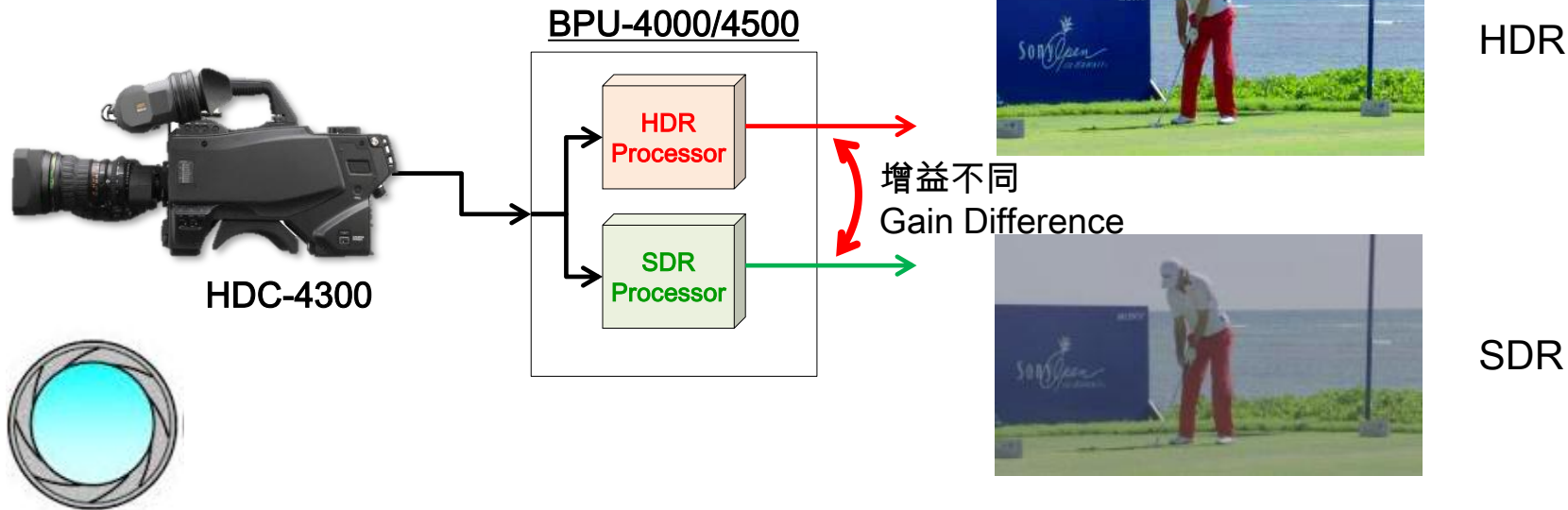

# 如何实现HDR/SDR同播制作？

## 如何在正常操作SDR时自动产生合适的HDR图像？

How can HDR/SDR Simul-production be made?

How operates in SDR domain create HDR image?

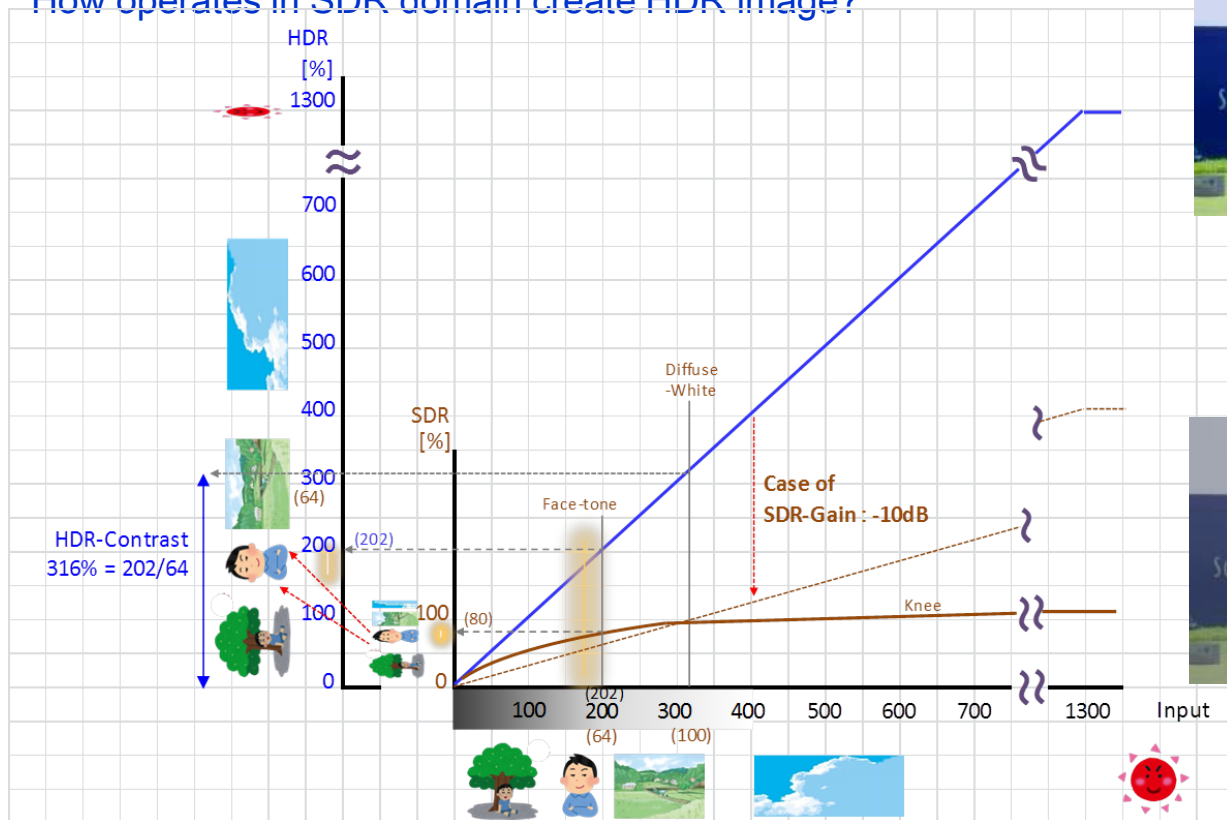



# 所需HDR/SDR同播制作的要点

## Required HDR/SDR Simul-Production Image

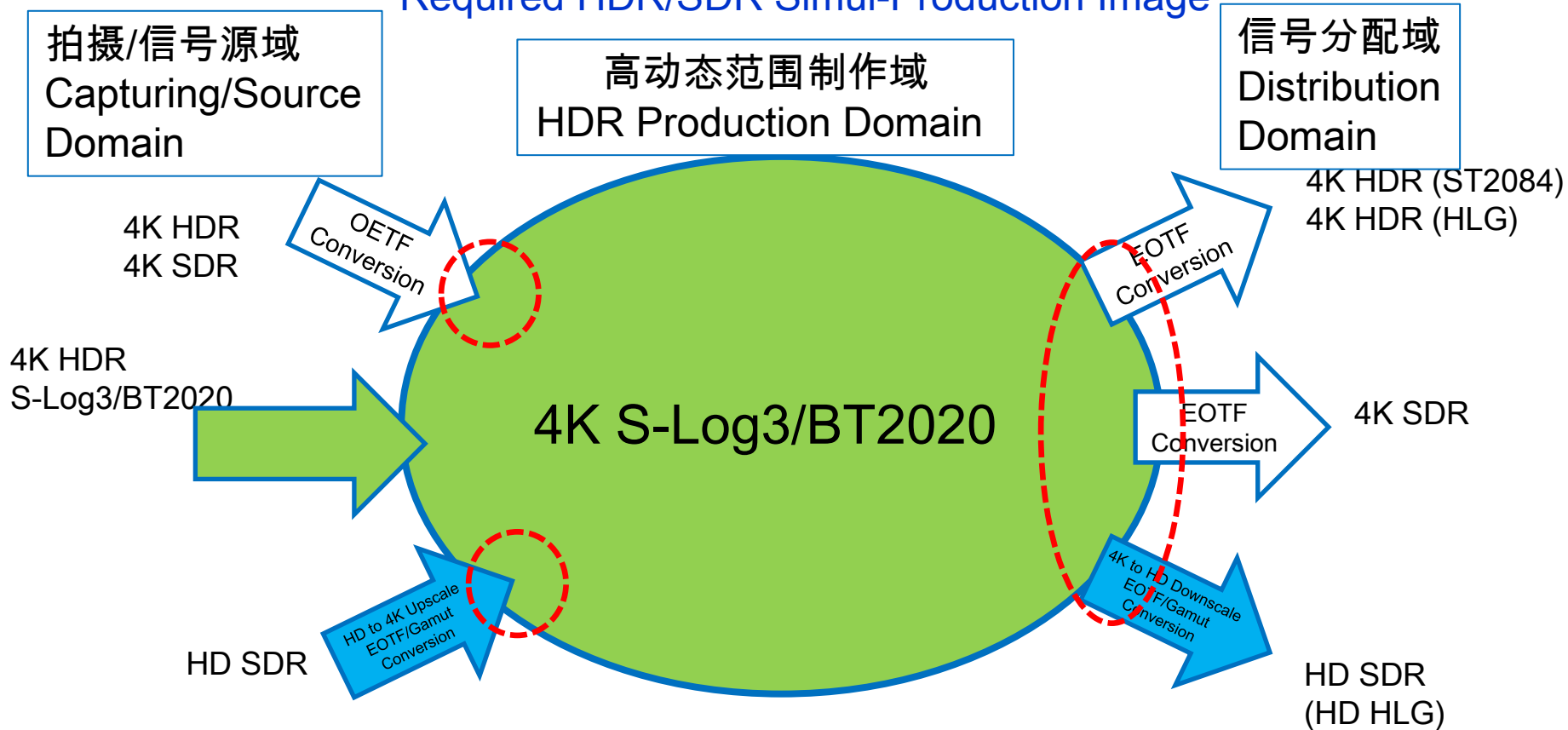

# 关键设备

The Key Player is:

## 高动态范围制作转换单元 HDR Production Converter Unit

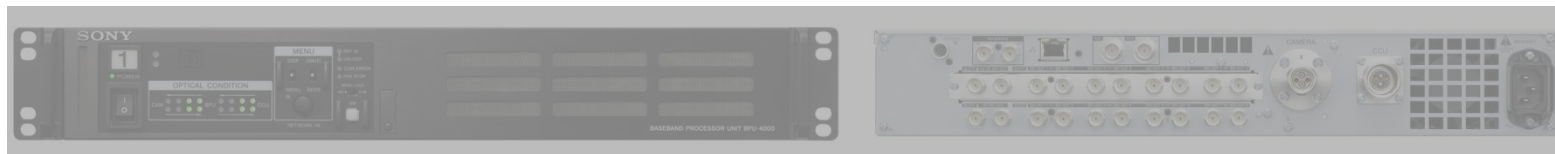

OETF/EOTF:

S-Log3

HLG

ST2084

Color Space:

BT709

BT2020

Spatial Rez:

1920x1080

3840x2160

*Listed Features are all TENTATIVE.*

# 信号用于各种 ( HDR/SDR ) 信号格式分配

Single Production for variable (HDR and SDR) distribution

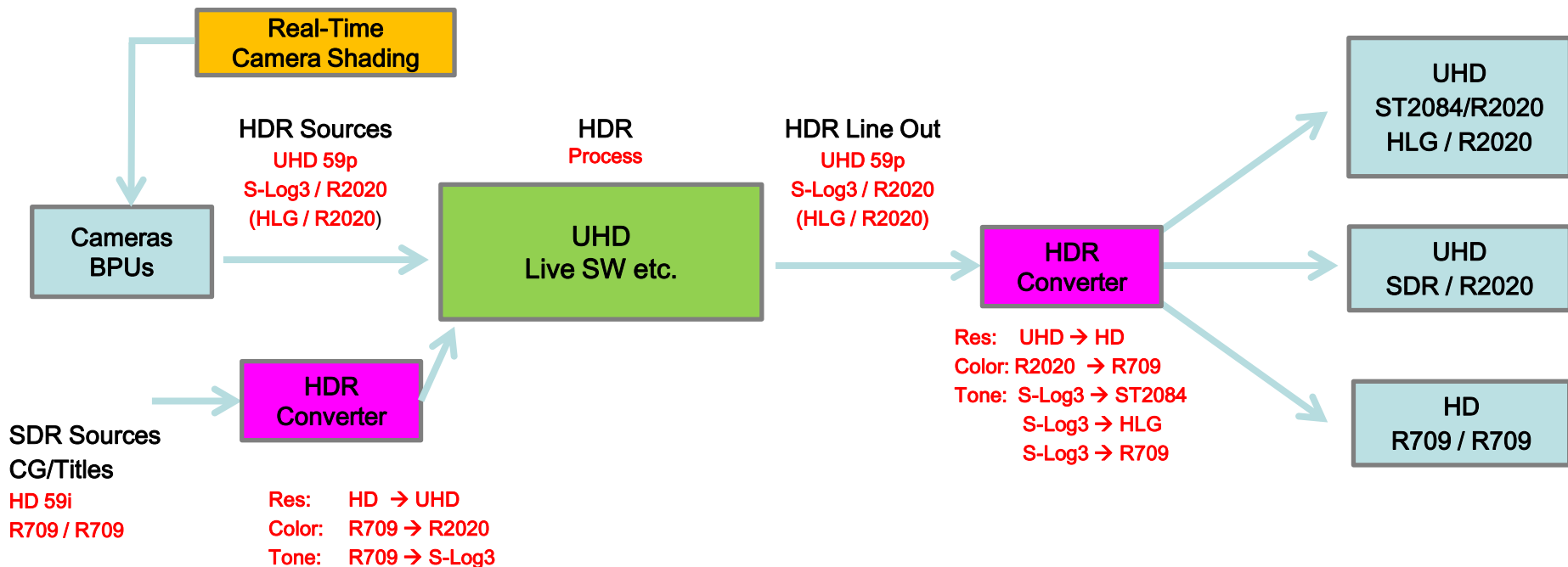

# 总结

## Summary

- ✓ HDR图像可以通过SDR域的信号处理进一步镜像调整优化
  - ✓ 重点同步预先设定的增益差

HDR Images can be optimized by painting images in SDR domain

Key is to defining gain difference between HDR and SDR

- ✓ HDR图像可以方便的转换为所需的EOTF ( 索尼提供HDR信号转换器 )

HDR images can be easily converted to the selected distribution EOTF by Sony's HDR Production Converter Box

- ✓ 提供从镜头到客厅屏幕的工作流程
  - ✓ 可以提供高质量的HDR图像到家庭收看端 ( 思科解码器 )
- ✓ Offers Glass-to-glass workflow
  - ✓ We can deliver superior HDR images to home by Cisco encoder

# 索尼4K现场制作产品线

Sony 4K live line-up

HDC-4300/BPU-4000



XVS-8000



PWS-4500



F55/BPU-4000

BVM-X300



HDC-4800/BPU-4800

✓ **HDR READY**

IP

# 4K/IP-HDR/SDR 现场制作系统

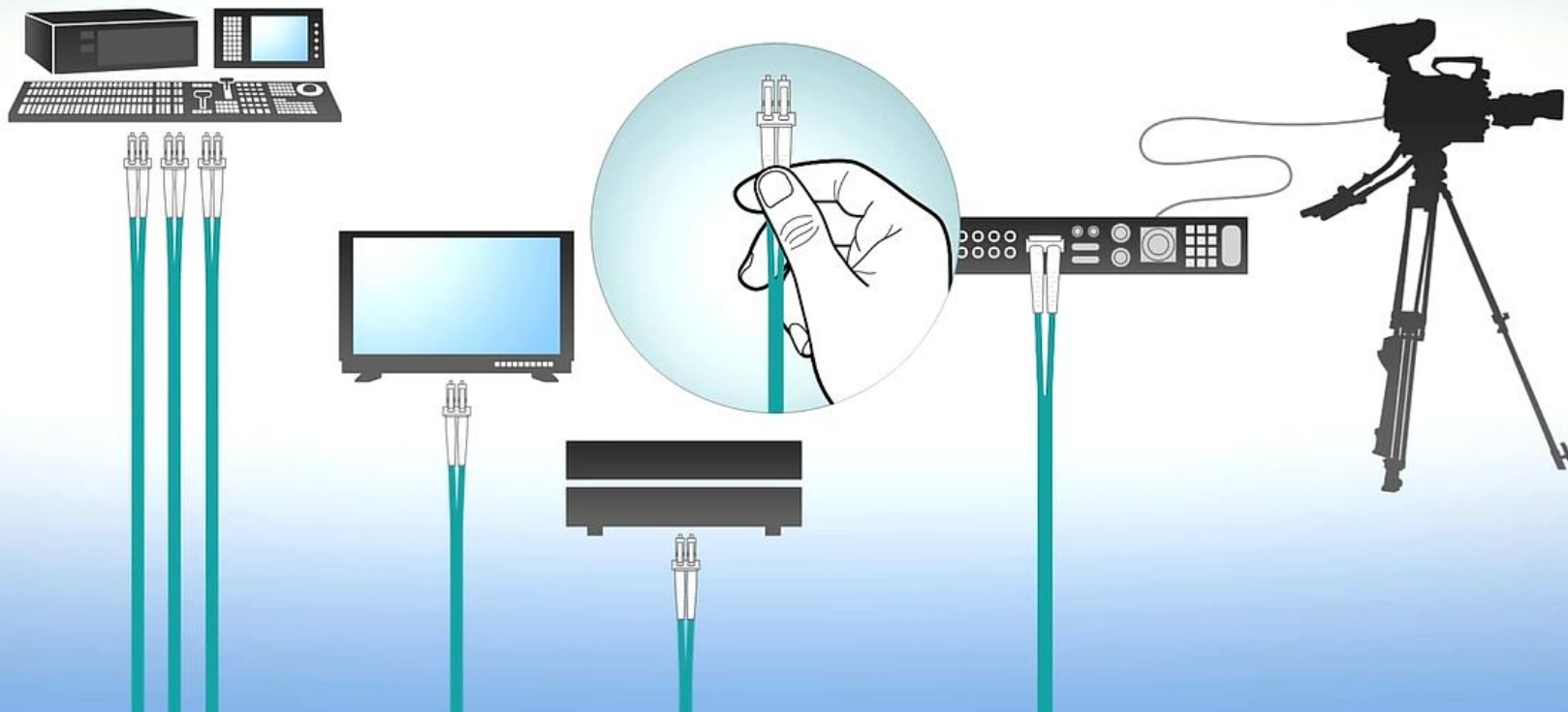

# 投入运营的索尼超高清/IP-现场制作系统

SONY

Actual installation UHD/(&IP)-Live system by Sony

## TV Globo 4K/IP OB Van

